

A Book to  
Honor the 80<sup>th</sup>  
Birthday of  
Prof. Dr. Ir.  
Wiratman  
Wangsadinata

# BEHAVIOR OF THE ORTHOTROPIC STIFFENED PLATE SUBJECTED TO LOCALIZED BLAST LOAD



Prof. Ir. Sofia W. Alisjahbana, M.Sc., Ph.D.  
Bakrie University  
Jakarta, Indonesia  
sofia.alisjahbana@bakrie.ac.id



Prof. Dr. Ir. Wiratman Wangsadinata  
President Director PT. Wiratman  
Jakarta, Indonesia  
wiratman@wiratman.co.id

**ABSTRACT:** This paper deals with the dynamic analysis and discussion of a damped orthotropic stiffened plate subjected to blast load. Analytical solutions of the dynamic deflection of the plate with fully fixed boundary conditions along its edges are presented by means of dealing with the governing differential equations. Numerical solutions for the natural frequencies and mode shapes are obtained by using the Modified Bolotin Method (MBM). Number of modes of the orthotropic plate are real numbers

and solved from transcendental equations. Special emphasis is focused on the dynamic deflection of mid-point displacements. The results obtained give an insight into the effect of the plate thickness; stiffeners configurations; the position of the blast load and the viscous damping on the dynamic response of the orthotropic plate and indicate that these factors affect their overall behavior. The interaction between the blast load and the orthotropic plate for all the cases mentioned in this paper are considered in the 3D simulation.

**KEY WORDS:**

Damped orthotropic stiffened plate,  
Blast load,  
Natural frequencies,  
Modified Bolotin Method,  
Transcendental equation,  
Stiffeners configuration,  
Viscous damping.

## **1. INTRODUCTION**

The dynamic behavior of a damped orthotropic stiffened plate under localized blast loads had been subject of studies for many years. In the analysis of rectangular orthotropic plates different models had been established and investigated by researchers. Much previous work in this area had involved one-way stiffened plates under intense loads (e.g. Schuback et al. 1989 and Olson 1991). Yuen and Nurick (2003) introduced numerical solutions of the dynamic response of the plate subjected to blast loading with different stiffeners configurations.

Louca and Pan (1999) analyzed the response of stiffened and unstiffened plates subjected to blast loading by using a single energy-based formulation.

There have been a few studies dealing with the response of simply supported plates subjected to blast load. The analysis of simply supported orthotropic plates subjected to static and dynamic loads were presented by Dobyns (1981) who analyzed the response to pulses of different shapes. Approximated numerical analysis of simply supported laminated composite plates subjected to blast

load was studied by Kazanci and Mecitoglu (2008), where the finite difference method was applied to solve the system of coupled nonlinear equations. Li et al. (2014) studied numerically the dynamic response of the rectangular plate subjected to moving loads. The simply supported boundary conditions were used in their model and the time histories of the deflection response corresponding to different conditions of dynamic load were also discussed.

In most of the works the type of plates considered were isotropic and rectangular which were uniform in all directions. In application not all plates are isotropic. Another important characteristic of the plate is its orthotropic nature, which found applications in the modelling of the dynamic response of concrete floors. Zhou et al. (2008) compared theoretical and experimental results for concrete slabs to blast loading. Cizelj et al. (2009) investigated a homogeneous isotropic rectangular plate clamped at all four sides to represent the wall segment subjected to a blast load by using a slightly modified handbook formula to estimate the response of the plate.

However, only a few cases in the dynamic response of fixed orthotropic damped plates subjected to blast loading have been investigated. Kadid (2008) investigated the behavior of a stiffened plate subjected to uniform blast loading. Numerical solutions were obtained in his study by using the finite element method and the central difference method for the time integration of the non-linear equations of motion.

The objective of this study is to present a general method that allows one to systematically analyze the dynamic behavior of damped orthotropic plates under localized blast load. The model adopted is a damped rectangular orthotropic plate with fully fixed boundary conditions at all edges subjected to a localized blast load. In this study, the analytical model of the problem is deduced from the normalized factor of the Eigen functions, derived by using the Modified Bolotin method. With this model, the dynamic response of the orthotropic plate can be investigated subjected to blast loads

with different positions. The influence of the thickness of the plate, stiffeners configuration, the position of the blast load and the viscous damping on the dynamic response of the plate are discussed, respectively.

## 2. SOLUTION OF THE GOVERNING EQUATION

In this section, a mathematical model for the damped orthotropic plate subjected to blast load is presented. The rectangular orthotropic plate with the length  $a$ , the width  $b$  and the thickness  $h$ , is depicted in **Figure 1**. The Cartesian axes are used in the derivation. By using the classical thin plate theory, the deflection of the damped orthotropic plate is governed by the following differential equation:

$$D_x \frac{\partial^4 w(x, y, t)}{\partial x^4} + 2H \frac{\partial^4 w(x, y, t)}{\partial x^2 \partial y^2} + D_y \frac{\partial^4 w(x, y, t)}{\partial y^4} + \rho h \frac{\partial^2 w(x, y, t)}{\partial t^2} + \gamma h \frac{\partial w(x, y, t)}{\partial t} = p(x, y, t) \quad (1)$$

where  $w(x, y, t)$  = transverse deflection of the plate at point  $(x, y)$  and time  $t$ ,  $D_x$  = the flexural stiffness in the  $x$ -direction,  $H$  = the torsional stiffness,  $D_y$  = the flexural stiffness in the  $y$ -direction,  $\rho$  = the mass density,  $h$  = the thickness of the plate,  $\gamma$  = the viscous damping.

The dynamic blast loading  $p(x, y, t)$  is written as:

$$p(x, y, t) = P(t) \delta[x - x(t)] \delta[y - y(t)] = P(t) \delta[x - x_0] \delta[y - y_0] \quad (2)$$

where  $\delta[.]$  = Dirac delta function;  $x_0$  = initial position of the blast load in  $x$ -direction;  $y_0$  = the initial position of the blast load in  $y$ -direction;  $P(t)$  = function describing the blast loading at time  $t$  defined as:

$$P(t) = P_0 \left( 1 - \frac{t}{t_d} \right) \quad (3)$$

where  $P_o$  = the maximum amplitude of the blast loading;  $t_d$  = duration of the blast loading.

In the Modified Bolotin Method an Eigen mode is initially approximated by a general solution consisting of trigonometric functions that can be expressed as (Pevzner et al. 2000):

$$(4) \quad w(x, y, t) = \sum_{m=1}^{\infty} \sum_{n=1}^{\infty} W_{mn}(x, y) T_{mn}(t)$$

where  $W_{mn}(x, y) = X_m(x, y) Y_n(y)$ ;  $X_m(x, y)$  and  $Y_n(y) = m$ th and  $n$ th modes of free vibration of the orthotropic plate in the  $x$ - and  $y$ -directions, respectively, which are given by:

$$(5) \quad X_m(x) = \cosh(F_1 x) + \left( \frac{bp(c_1 - C_1)}{-\beta s_1 + bpS_1} \right) \sinh(F_1 x) - \cos(F_2 x) - \left( \frac{\beta(-c_1 + C_1)}{\beta s_1 - bpS_1} \right) \sin(F_2 x)$$

$$(6) \quad Y_n(y) = \cosh(F_3 y) + \left( \frac{bq(c_2 - C_2)}{-\theta s_2 + bqS_2} \right) \sinh(F_3 y) - \cos(F_4 y) - \left( \frac{\theta(-c_2 + C_2)}{\theta s_2 - bqS_2} \right) \sin(F_4 y)$$

where  $a$  = the width of plate in the  $x$ -direction;  $b$  = the width of plate in the  $y$ -direction;  $F_1, F_2, F_3$  and  $F_4$  = frequency parameter associated with each orthotropic plate which are given in the Appendix and  $p$  and  $q$  are real numbers such that  $m \leq p \leq m+1$  and  $n \leq q \leq n+1$ .

The unknown quantities  $p$  and  $q$  are calculated by solving the system of transcendental equations which satisfy the boundary conditions as follows (Alisjahbana, S.W. and Wangsadinata, W. 2012):

$$(7) \quad \frac{\pi}{a^2 b^2} \left( 2bp\beta - 2bp\beta \cos(p\pi) \cosh\left(\frac{\pi\beta}{b}\right) - (b^2 p^2 - \beta^2) \sin(p\pi) \sinh\left(\frac{\pi\beta}{b}\right) \right) = 0$$

$$(8) \quad \frac{\pi}{a^2 b^2} \left( 2aq\theta - 2aq\theta \cos(q\pi) \cosh\left(\frac{\pi\theta}{a}\right) - (a^2 q^2 - \theta^2) \sin(q\pi) \sinh\left(\frac{\pi\theta}{a}\right) \right) = 0$$

The total dynamic deflection of the system can be solved by using the Duhamel integration method that can be expressed as (Alisjahbana, S.W. and Wangsadinata, W. 2012):

$$w(x, y, t) = \sum_{m=1}^{\infty} \sum_{n=1}^{\infty} \left[ e^{-\gamma \omega_{mn} t} (a_{mn} \cos(\omega d_{mn} t) + b_{mn} \sin(\omega d_{mn} t)) \right] + \sum_{m=1}^{\infty} \sum_{n=1}^{\infty} \left[ X_m(x, y) Y_n(x, y) \right] \frac{\int_0^a X_m(x, y) dx \int_0^b Y_n(x, y) dy}{\rho h Q_{mn}(\omega d_{mn})} \int_0^t p(x, y, \tau) e^{-\gamma \omega_{mn}(t-\tau)} \sin(\omega d_{mn}(t-\tau)) d\tau \quad (9)$$

where  $a_{mn}$  and  $b_{mn}$  are constants that are determined from the initial conditions,  $Q_{mn}$  is the orthogonally factor,  $p(x, y, \tau)$  is the dynamic load and  $\omega d_{mn}$  is the damped natural frequency of the system that are given in the Appendix.

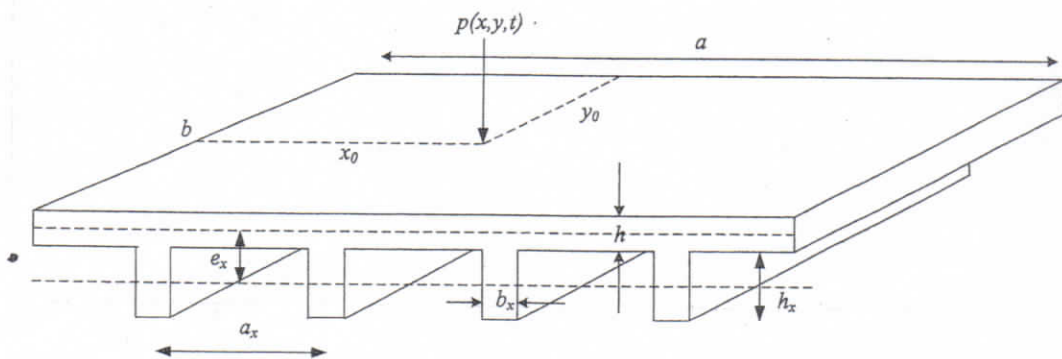

Figure 1. Orthotropic plate subjected to localized blast load.

### 3. NUMERICAL CALCULATION

Based on the theory presented in the previous section, numerical calculation are carried out to illustrate the dynamic deflection response of an orthotropic stiffened plate subjected to the localized blast load. The adopted material properties for the orthotropic plate are  $a = 5.5$  m,  $b = 4.5$  m,  $E = 210$  GPa,  $\nu = 0.2$ ,

$a_x = 2.75$  m,  $b_x = 0.2$  m,  $P_0 = 1.3$  MPa (Kadid 2008). In order to study the effect of plate thickness, stiffeners configuration and the position of the localized blast load to the dynamic response of the plate, three models of plate have been used in this work as follows: model 1,  $h = 16$  cm; model 2,  $h = 18$  cm and model 3,  $h = 20$  cm. The Modified Bolotin Method (MBM) has been applied to obtain the natural frequencies of the system for the first four modes in the  $x$ -direction ( $m = 1, 2, \dots, 4$ ) and for the first five modes in the  $y$ -direction ( $n = 1, 2, 3, \dots, 5$ ) as shown in **Table 1**.

**Table 1.** Fundamental frequencies and number of mode.

$m$	$n$	$\omega$ (rad/s)	$\omega$ (rad/s)	$\omega$ (rad/s)	$\omega$ (rad/s)	$\omega$ (rad/s)	$\omega$ (rad/s)
		MODEL 1	MODEL 2	MODEL 3	MODEL 1	MODEL 2	MODEL 3
		without stiffeners			1 stiffener		
1	1	695.482	770.504	846.952	741.784	811.812	884.395
	2	1592.71	1710.94	1893.64	1564.78	1740.78	1919.59
	3	2812.51	3154.72	3498.4	2843.68	3180.63	3520.48
	4	4528.82	5085.85	5644.37	4558.19	5109.95	5664.65
	5	6683.13	7509.2	8336.77	6713.5	7533.75	8357.39
2	1	1353.78	1481.27	1612.94	1517.36	1631.82	1752.92
	2	2118.85	2344.62	2575.35	2262.11	2471.08	2688.83
	3	3368.06	3751.86	4141.04	3496.94	3862.05	4237.24
	4	5068.37	5665.78	6268.79	5188.88	5766.74	6355.32
	5	7207.13	8072.54	8943.67	7322.59	8168.02	9024.52
3	1	2398.94	2614.84	2838.52	2732.35	2925	3129.47
	2	3114.5	3420.62	3736.13	3428.56	3704.72	3996.29
	3	4317.04	4775.05	5243.74	4610.01	5032.36	5473.51
	4	5986.43	6654.51	7334.12	6262.9	6891.68	7541.62
	5	8105.81	9040.24	9986.02	8370.61	9263.15	10178.3
4	1	3806.42	4142.95	4491.87	4363.79	4663.88	5046.02
	2	4493.6	4915.08	5351.09	5034.02	5410.65	5810.23
	3	5656.2	6223.01	6806.57	6173.83	6686.6	7227.44
	4	7289.45	8061.1	8851.23	7784.96	8495.04	9237.67
	5	9381.32	10415.3	11469.0	9858.44	10825.4	11828.3

**Table 1** shows the natural frequencies of the orthotropic plates for different values of thickness and stiffeners configuration. It is shown that by increasing the plate thickness as well as adding the stiffener, the natural frequency of the system increases.



### 3.1 EFFECT OF PLATE THICKNESS

By increasing the thickness of the orthotropic plate, the mid-point deflection of the plate will decrease significantly. The mid-point deflection for model 1 without stiffener subjected to a blast load with  $t_d = 2$  ms,  $x_0 = a/2$  and  $\gamma = 5\%$  is 0.00517138 m, for model 2 the mid-point deflection is 0.0039278 m, while the mid-point deflection for model 3 is 0.00306756 m. Therefore, by increasing the thickness of the plate by 2 cm, the mid-point deflection will decrease by 24.05%. In conclusion, the thickness of the plate plays an important role in determining the level of response of the orthotropic plate as shown also in **Figure 4**.

### 3.2 EFFECT OF PLATE STIFFENER

As shown in **Table 2**, for model 1 with  $t_d = 2$  ms and  $(x_0, y_0) = (a/2, b/2)$  adding 1 stiffener parallel to the  $x$ -axes, has resulted in a decrease in the mid-point displacement of the plate by 17.06% as compared to the mid-point displacement of the plate without stiffener. In **Figure 2** and **Figure 3**, the effect of stiffener is illustrated clearly for all the cases; that is, the deflection responses and the internal forces will decrease when a stiffener is added into the system.

**Table 2.** Total dynamic deflection of the orthotropic plate to localized blast load,  $t_d = 2$  ms,  $\gamma = 5\%$ .

$x_0$	MODEL 1	MODEL 2	MODEL 3	MODEL 1	MODEL 2	MODEL 3
	$w$ max (m)	$w$ max (m)	$w$ max (m)	$w$ max (m)	$w$ max (m)	$w$ max (m)
	without stiffeners			1 stiffener		
$a/8$	0.00104959	0.000134375	0.000692786	0.00137569	0.00111798	0.000898581
$2a/8$	0.00247588	0.00194307	0.00155419	0.00147865	0.00234992	0.00199192
$3a/8$	0.00424792	0.00326408	0.00252964	0.0034592	0.00319664	0.00257393
$4a/8$	0.00517138	0.0039278	0.00306756	0.00428886	0.00397082	0.00306262

### 3.3 EFFECT OF POSITION OF THE BLAST LOAD

Effect of the position of the blast load on the orthotropic plate response is investigated. The maximum dynamic deflection of the

system at the center of the plate  $w(a/2, b/2, t)$  is calculated and plotted for different positions of the blast load.

In **Figure 2** and **Figure 4**, the effect of the position of the load is illustrated clearly for all the cases; that is, the maximum dynamic deflection response increases when the position of the blast load becomes closer to the mid-span of the orthotropic plate. It has been shown that the maximum deflections are always located under the load and at the mid-span of the system (Huang and Thambiratnam 2001).

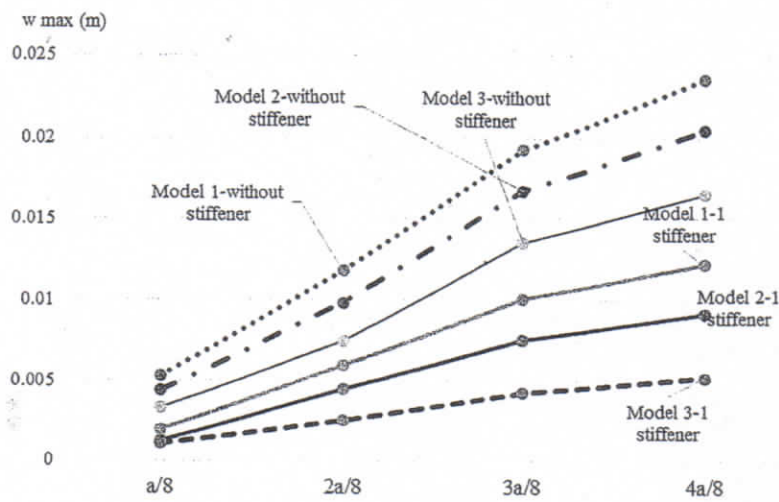

**Figure 2.** Maximum dynamic deflection to blast loading as a function of the position in the  $x$ -direction. Parametric loading:  $t_d = 2$  ms,  $\gamma = 5\%$ .

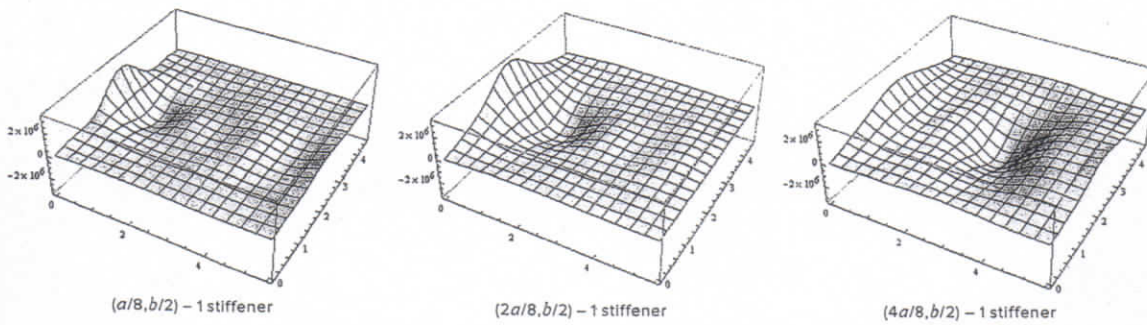

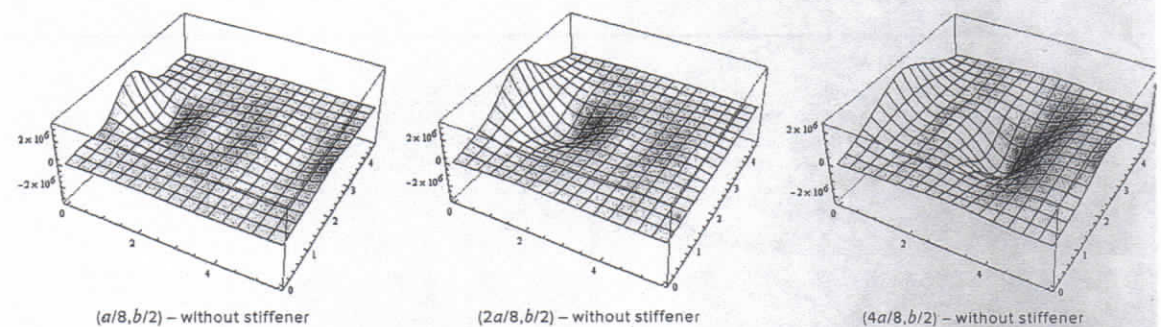
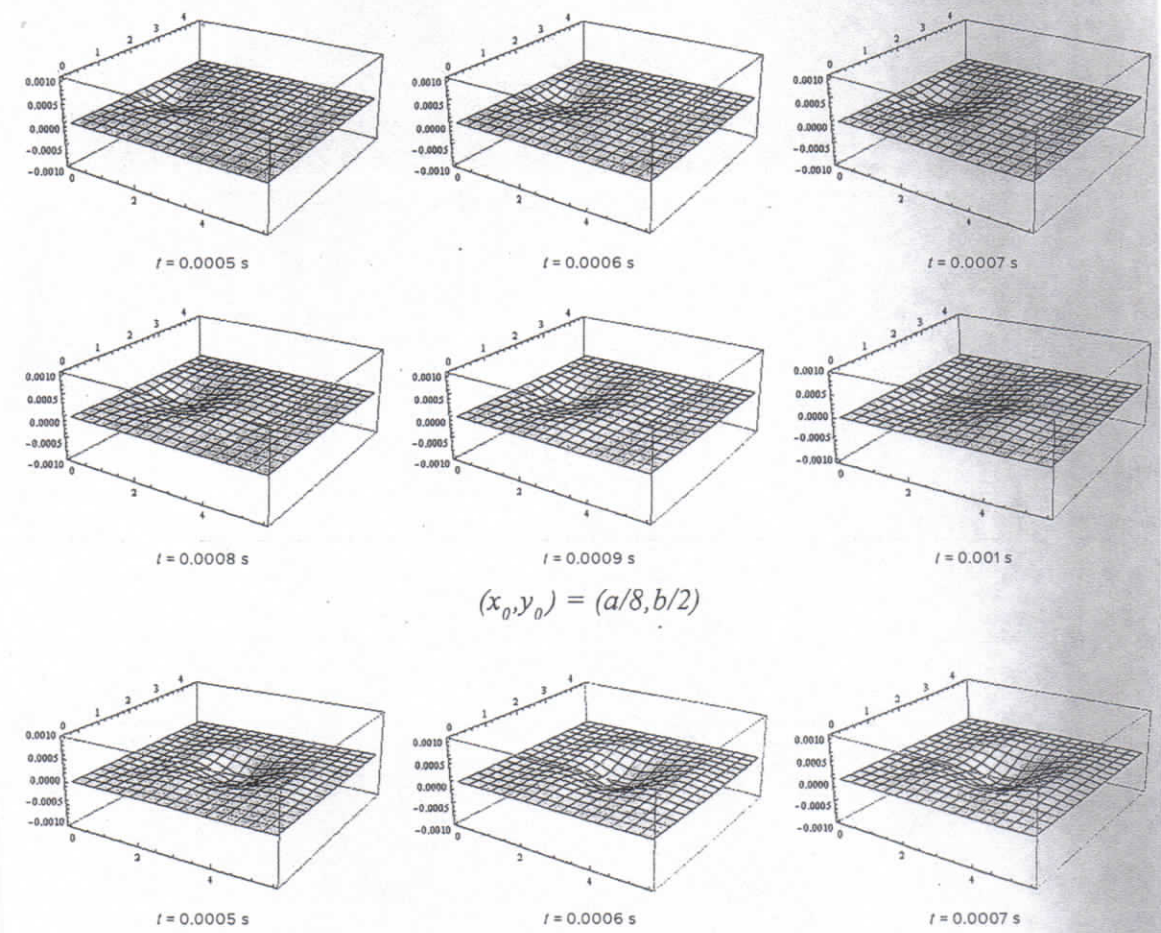

Figure 3. Three dimensional moment- $x$  distribution as a function of the position of the blast loading in the  $x$  direction ( $\gamma = 5\%$ ,  $t_{eff} = 2$  ms).



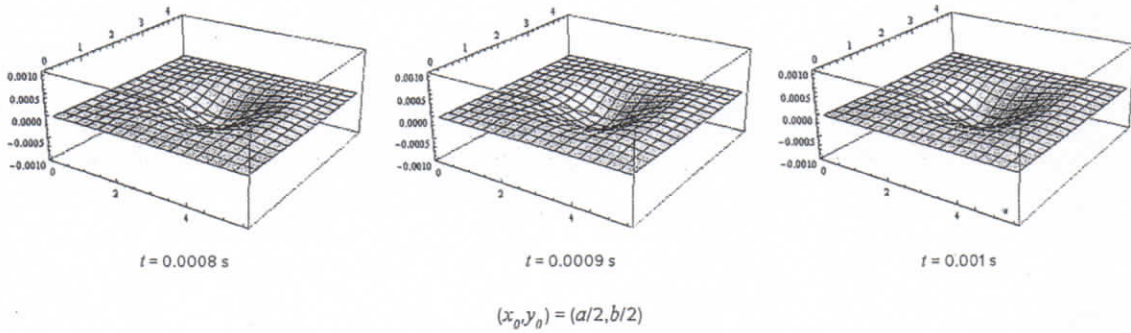
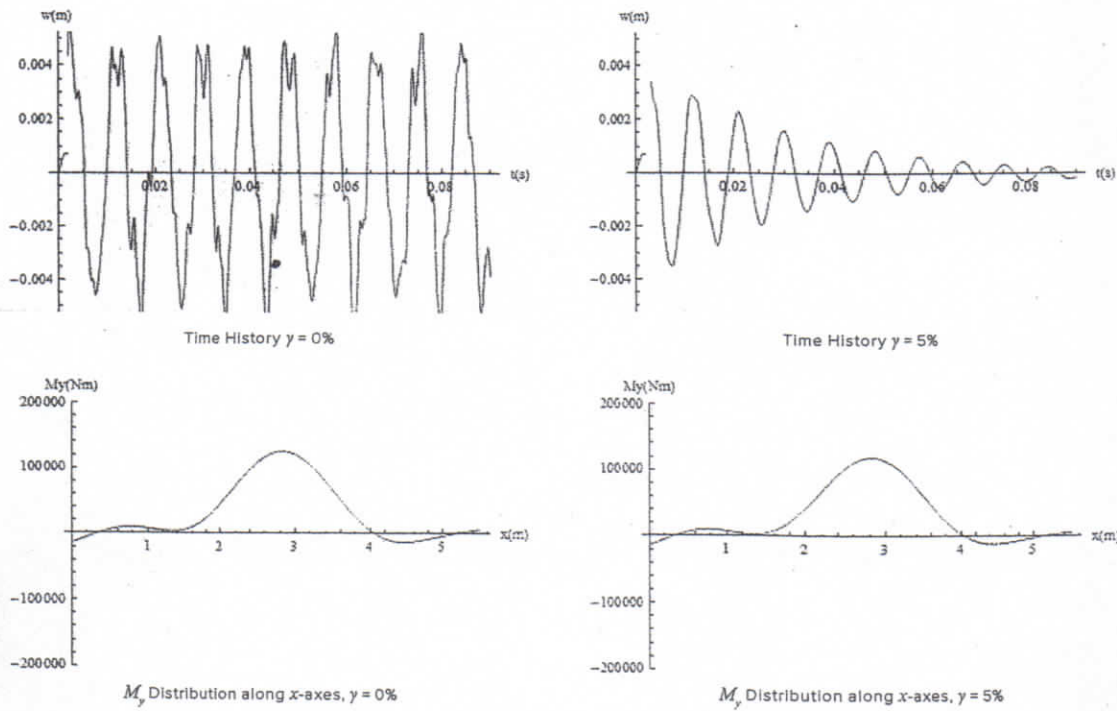

Figure 4. Dynamic deformation of model 1 with 1 stiffener subjected to localized blast load ( $t_d = 2$  ms).

### 3.4 EFFECT OF VISCOUS DAMPING

In Figure 5, the effect of viscous damping is illustrated clearly for model 1 with 1 stiffener. The deflection response as well as the internal bending moment and shear force time history will decrease when viscous damping becomes higher.



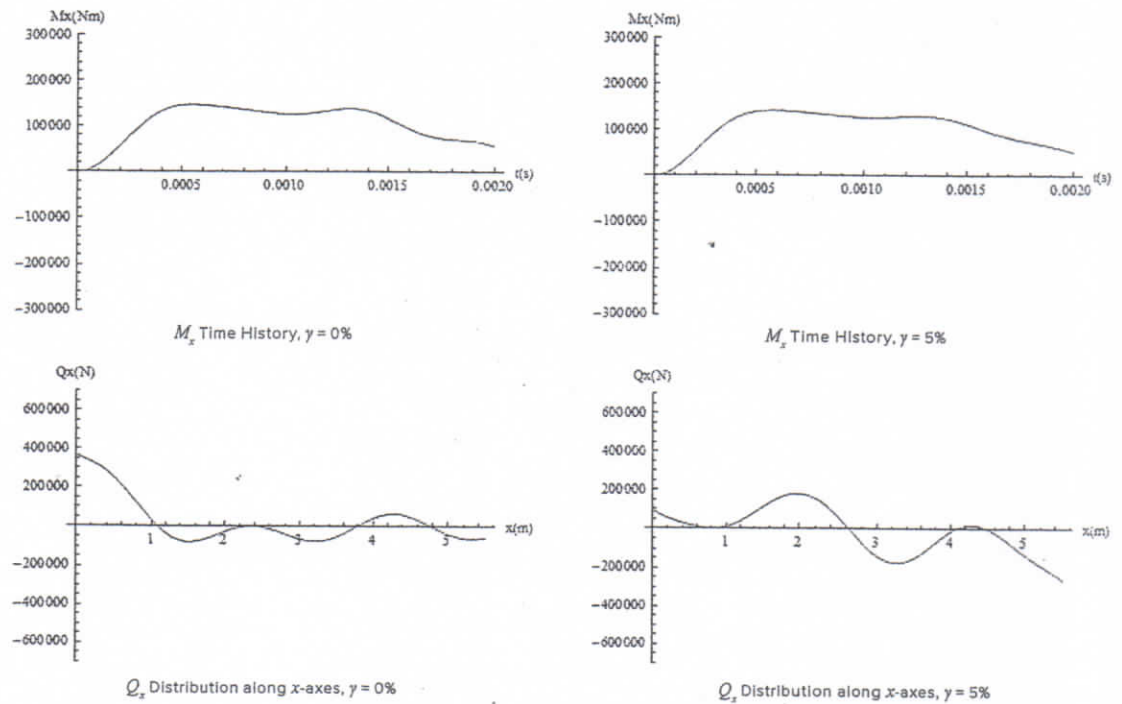

Figure 5. Response of orthotropic stiffened plate for model 1 subjected to a blast loading ( $t_d = 2$  ms).

## 5. CONCLUSIONS

An analytical solution for the dynamic response of a rectangular orthotropic plate with fully fixed supported boundary conditions is discussed in this paper. The deflection distribution of the plate and the effects of the plate thickness, the stiffener configuration, the position of the blast load and the viscous damping on the response of the plate are illustrated and analyzed. The results obtained in this paper are meaningful and applicable to real cases that can be summarized as follows:

- The effect of the plate thickness and the stiffener configuration on the response of the plate is very important, since it affects drastically the overall behavior of the plate especially if a stiffener is added into the system.

- The position of the blast load is one of the important parameters since it has an influence on the maximum dynamic deflection of the plate.
- Viscous damping plays a very significant role in the vibration of plate structures, as it has been shown that the dynamic deflection, the external bending moments and the shear force profiles depend greatly on the damping ratio.

To obtain a more accurate result, experimental approach should be conducted to create better understanding of blast loading and the significance of the plate thickness and the stiffener configurations.

#### APPENDIX. EXPRESSIONS USED IN THE PAPER

The following expressions are used in this paper:

$$F_1 = \frac{\beta\pi}{ab}, F_2 = \frac{p\pi}{ab}, F_3 = \frac{\theta\pi}{ab}, F_4 = \frac{q\pi}{ab}, \beta = \sqrt{\frac{2Hq^2a^2}{D_x} + p^2b^2}, \theta = \sqrt{\frac{2Hp^2b^2}{D_y} + q^2a^2}$$

$$C_1 = \cosh\left(\frac{\pi\beta}{b}\right), c_1 = \cos(p\pi), S_1 = \sinh\left(\frac{\pi\beta}{b}\right), s_1 = \sin(p\pi)$$

$$C_2 = \cosh\left(\frac{\pi\theta}{a}\right), c_2 = \cos(q\pi), S_2 = \sinh\left(\frac{\pi\theta}{a}\right), s_2 = \sin(q\pi)$$

$$\omega d_{mn} = \omega_{mn} \sqrt{1 - \gamma^2}, \omega_{mn}^2 = \left( \frac{H}{\rho h} \left( \frac{D_x}{H} \left( \frac{p\pi}{a} \right)^4 + 2 \left( \frac{p\pi}{a} \right)^2 \left( \frac{q\pi}{b} \right)^2 + \frac{D_y}{H} \left( \frac{q\pi}{b} \right)^4 \right) \right)$$

#### REFERENCES:

- Alisjahbana, S.W. and Wangsadinata, W. (2012), "Response of Orthotropic Plates to localized blast load", *Research, Development, and Practice in Structural Engineering and Construction*, Perth, Australia, November.
- Alisjahbana, S.W. and Wangsadinata, W. (2012), "Dynamic analysis of rigid roadway pavement under moving traffic loads with variable velocity", *International and Multiscale Mechanics*, 5(2), 105-114.
- Cizelj, L. et al. (2009), "A method for rapid vulnerability assessment of structures loaded by outside blasts", *Nuclear Engineering and Design*, 239(2009), 1641-1646.
- Dobyns, A.L. (1981), "Analysis of simply-supported orthotropic plates subject to static and dynamic loads", *AIAA Journal*, 19(1981), 642-650.
- Huang, M.H., and Thambiratnam, D.P. (2001), "Deflection response of plate on Winkler foundation to moving accelerated loads", *Eng. Struct.*, 23(9), 1134-1141.
- Kadid, A. (2008), "Stiffened plates subjected to uniform blast loading", *Journal of Civil Engineering and Management*, 14(3), 155-161.
- Kazanci, Z. and Mecitoglu, Z. (2008), "Non-linear dynamic behavior of simply supported laminated composite plates subjected to blast load", *Journal of Sound and Vibration*, 317(2008), 883-897.
- Li, Mingliang et al. (2014), "Dynamic response of the rectangular plate subjected to moving loads with variable velocity", *Journal of Eng. Mech.*, 140(4), 06014001-1-06014001-7.
- Olson, M.D. (1991), "Efficient modelling of blast loaded stiffened plate and cylindrical shell structures", *Computers and Structures*, 40(5), 1139-1149.
- Pan, Y., and Louca, L.A. (1999), "Experimental and numerical studies on the response of stiffened plates subjected to gas explosions", *Journal of Constructional Steel Research*, 52(2), 171-193.
- Pevzner et al. (2000), "Further Modification of Bolotin method in vibration analysis of rectangular plates", *AIAA Journal*, 38(9), 1725-1729.
- Schubak et al. (1989), "Nonlinear Analysis of One-way Stiffened Plates under Blast Load", *Proceeding of the 1<sup>st</sup> International Conference "Structures under Shock and Impact"*, Cambridge, M.A., USA, July.
- Yuen, S.C.K., and Nurick, G.N. (2003), "Experimental and numerical studies on the response of quadrangular stiffened plates, Part I: subjected to uniform blast load", *International Journal of Impact Engineering*, 31(1), 55-83.
- Zhou, X.Q. et al. (2008), "Numerical prediction of concrete slab response to blast loading", *International Journal of Impact Engineering*, 35(2008), 1186-1200.

Published by

**WITness Press**

Graha Simatupang Tower II Blok A & D

Jl. Letjen T.B. Simatupang Kav. 38, Jakarta 12540

Telp. 021 7817777 (Hunting) Fax. 021 7829370

[WWW.WIRATMAN.CO.ID](http://WWW.WIRATMAN.CO.ID)

ISBN 978-602-72044-0-9



9 786027 204409